



# *Company Overview Presentation*

**World's Fastest, Most Reliable  
Nonvolatile Memory**

- **Corporate Overview**

- **Headquarters: Colorado Springs, CO**
- **Founded 1987**
- **Publicly traded (SMTK)**
- **Fabless semiconductor company**
  - R&D, Product Design, Production engineering, Process Development, Marketing & Sales
  - Subcontract silicon wafer fabrication, packaging, test
- **ISO 9001:2000 Certified**
- **Products**
  - Nonvolatile Static RAMs (nvSRAM)
- **Full Time Employees: 65**

# Executive Management



# Significant Revenue Growth

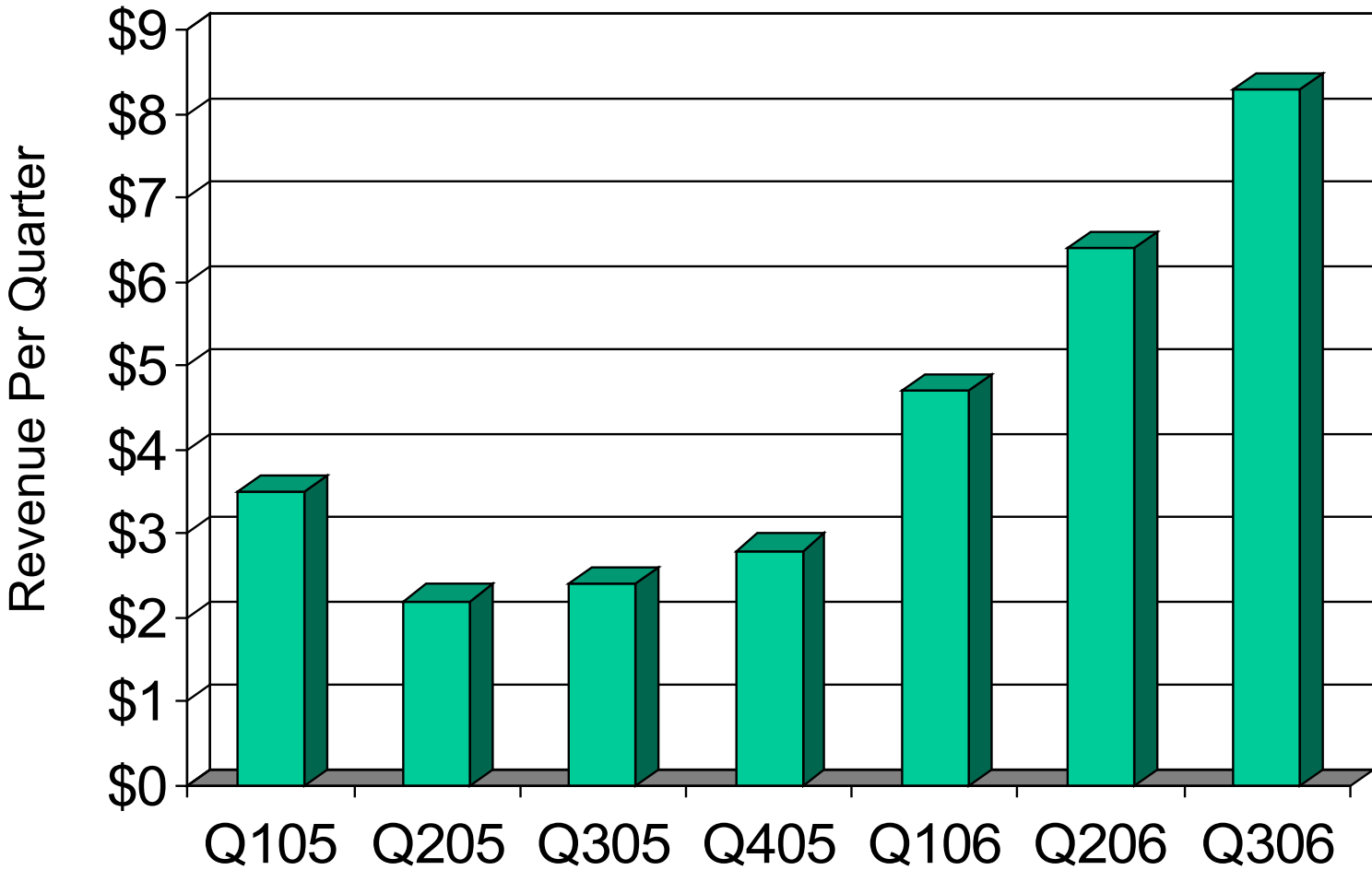



- ★ Wafer Fabrication
- ★ Package Assembly
- ★ Test

- Corporate Overview
- **Product Introduction**

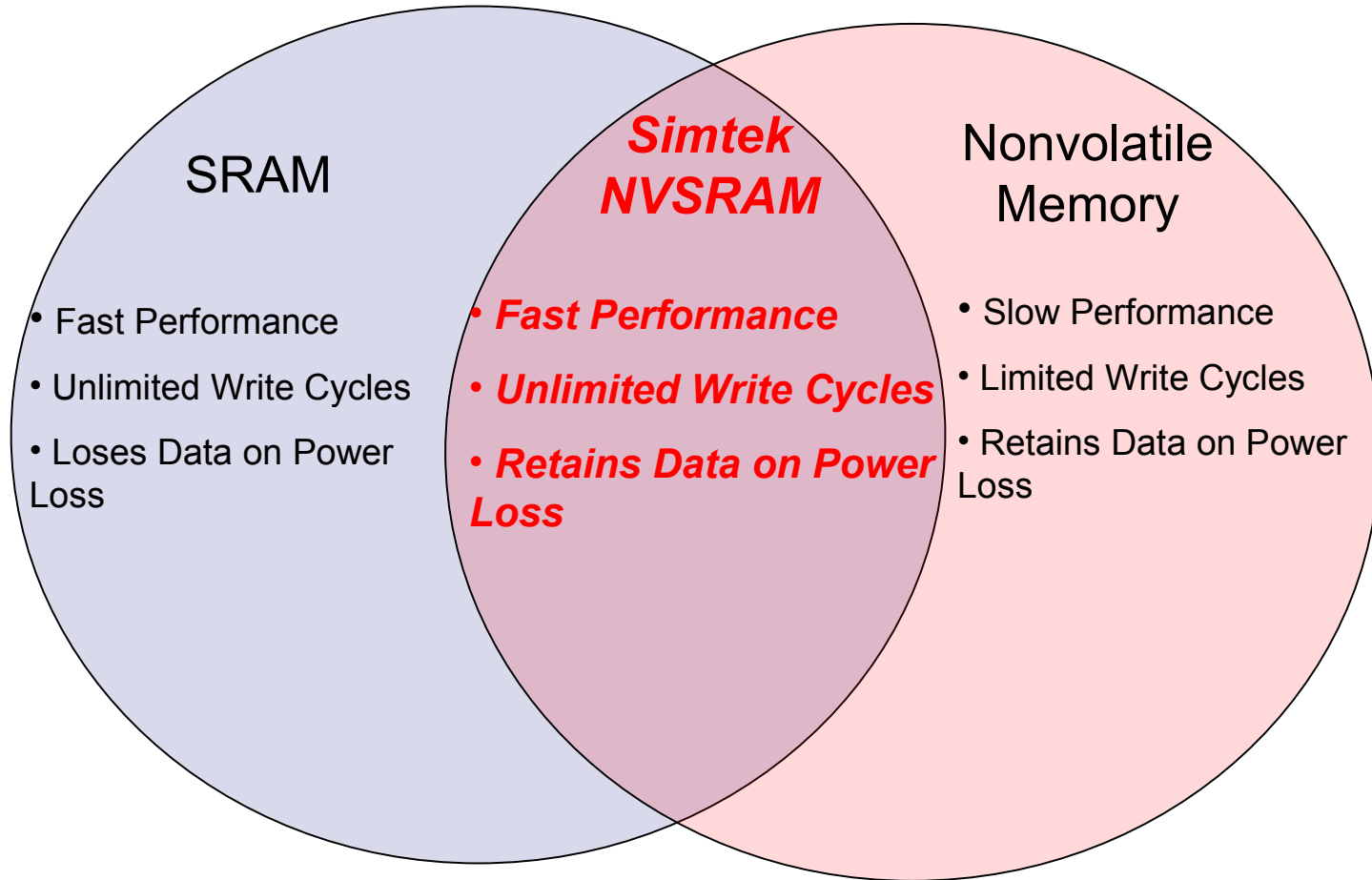

# Where would a NVSRAM be used?

Situation	Desired Outcome	Key Simtek Feature
#1	Record or log continuously written data and occasionally store it	Unlimited Read and Writes Software/Hardware Store
#2	Automatically save critical data during a power loss	Autostore

Application	Examples
Storage	Save storage system data in case of a power loss
Copiers	Record billing and maintenance information
Casino Slot Machines	Record player totals and retain in case of a power loss

- **16Kbit through 1Mb densities**
- **Fastest access times in the industry (25ns to 55ns)**
  - Can be written in real time without slowing down the system
- **Unlimited reads and writes**
  - Can be updated constantly without wearing out
- **Automatic store of SRAM data during a power loss**
- **20+ year data retention and 500K write cycles**
- **Product options with integrated Real-Time Clocks (RTC)**
- **Easiest and most flexible non volatile memory to design into systems**
  - Simple SRAM operation

- **Hardware**
  - Pull the pin ( $\overline{\text{HSB}}$ ) low
- **Software**
  - Use a specific address sequence for initiating nonvolatile storage
- **AutoStore**  **The Most Popular**
  - At power-down, the nonvolatile storage is done automatically
  - Uses an external capacitor
- **AutoStorePlus**
  - At power-down, the nonvolatile storage is done automatically
  - Capacitor embedded inside the package



# The Many Benefits To NVSRAM Technology

Customer Benefits	Reasons
Lower System Cost	<ul style="list-style-type: none"> <li>• Elimination of battery</li> </ul>
Higher Reliability	<ul style="list-style-type: none"> <li>• Elimination of the snap pack for the battery</li> <li>• Elimination of potential corrosive material</li> <li>• Elimination of potential battery failure</li> </ul>
Higher Performance Higher IOPs	<ul style="list-style-type: none"> <li>• The fastest write and read access available</li> </ul>
Smaller Board Space	<ul style="list-style-type: none"> <li>• Elimination of battery and accompanying hardware</li> </ul>
Simplified hardware and firmware design	<ul style="list-style-type: none"> <li>• No specialized write procedures, easy on F/W</li> <li>• No need to gauge battery life and develop scheme for data recovery after power loss</li> </ul>
ROHS Compliance	<ul style="list-style-type: none"> <li>• No leaded battery</li> </ul>
Improved Manufacturing	<ul style="list-style-type: none"> <li>• Eliminates additional battery inventory</li> <li>• Eliminates “shelf” life issue on stored batteries</li> </ul>



# Simtek nvSRAM Product Line

Memory Size (bits)	Part #	# of Pins	Initiated Store	R/W Access Times (ns)	Temp Range (C/I/M)	Voltage
16K	STK22C48	28	AutoStore	25 - 45	C/I	5
64K	STK11C68	28	S/W	25 - 45	C/I/M	5
	STK12C68	28	AutoStore			
256K	STK11C88	28	S/W	25 - 45	C/I	5 V
	STK14C88	32	AutoStore		C/I/M	5 V
	STK14C88-3	32	AutoStore	35 - 55	C/I	3.3 V
	STK14D88	32/48	AutoStore	25 - 45		3.0 V
	STK15C88	28	AutoStore			5 V
	STK16C88	28	AutoStorePlus			5 V
	STK16C88-3	28	AutoStorePlus	35 - 45		3.3 V
256K+ RTC	STK17T88	48	AutoStore	25 - 45	C/I	3 V
1M	STK14CA8	32/48	AutoStore	25 - 45	C/I	3.0 V
1M + RTC	STK17TA8	48	AutoStore	25 - 45	C/I	3.0 V

- Corporate Overview
- Product Introduction
- **Product Roadmap**

- **Larger nvSRAMs**
- **Pin-compatible family from 1 Mb to 8 Mb**
- **15 ns access times**
- **Increase data width to x16**
- **Pin-compatible family for integrated RTC functions**

## SONOS Technology Roadmap

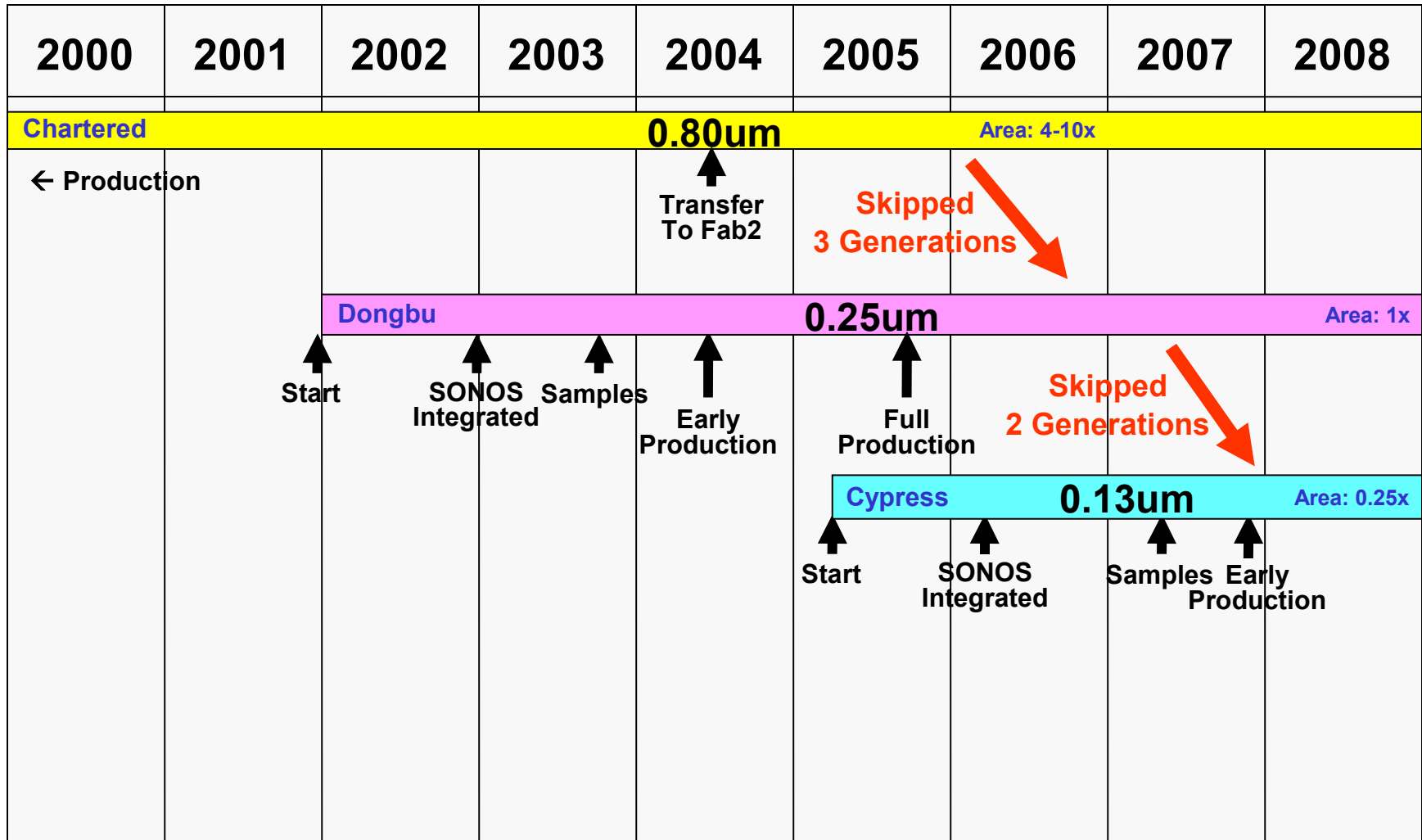

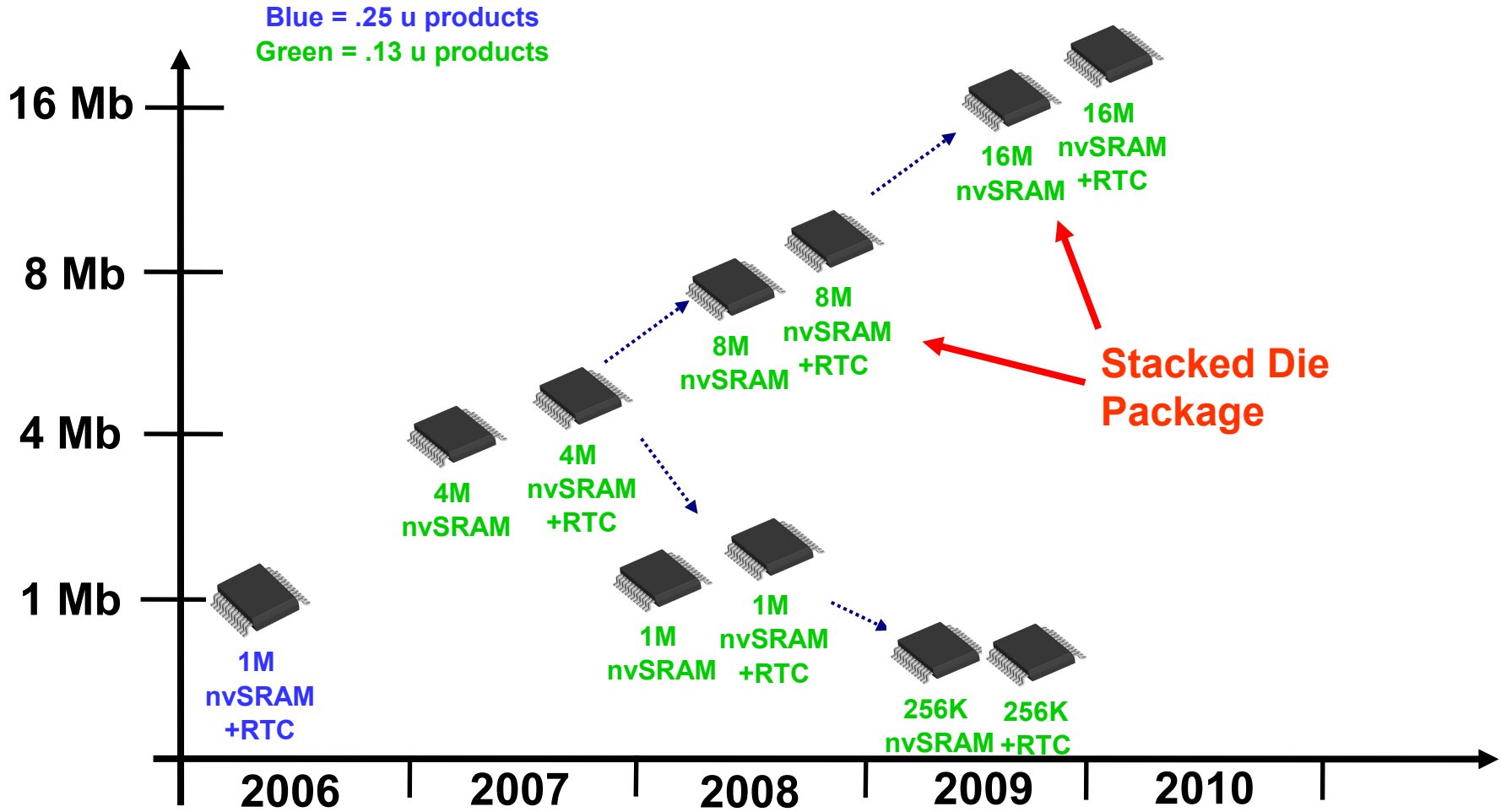

- Simtek nvSRAM is the only non-volatile with infinite writes and reads, combining the speed of SRAM and nonvolatile storage without the use of battery.
- Nonvolatile storage happens automatically during power loss.
- Used in a variety of applications where continual write of data and preventing data loss is important, under any potential power loss problem.
- Sample systems using nvSRAM are server storage, storage arrays, networks, medical devices, industrial control, copiers, avionics, GPS systems, automated meter reading (AMR), casino gaming machines, and POS systems.
- Powerful roadmap for future products planned in concert with process technology shrinks from 130 nm to 65 nm.

- Corporate Overview
- Product Introduction
- Product Roadmap
- **Competition**

Parameter	FLASH	EEPROM	SRAM	BBSRAM	FRAM	SIMTEK nvSRAM
Nonvolatile	X	X		X	X	X
Unlimited Endurance	100K	1000K	X	X		X
Random Access			X	X	X	X
No Battery Needed	X	X	X		X	X
Fast Read & Write (25 - 45 nsec)			X			X
Byte Programmable		X	X	X	X	X

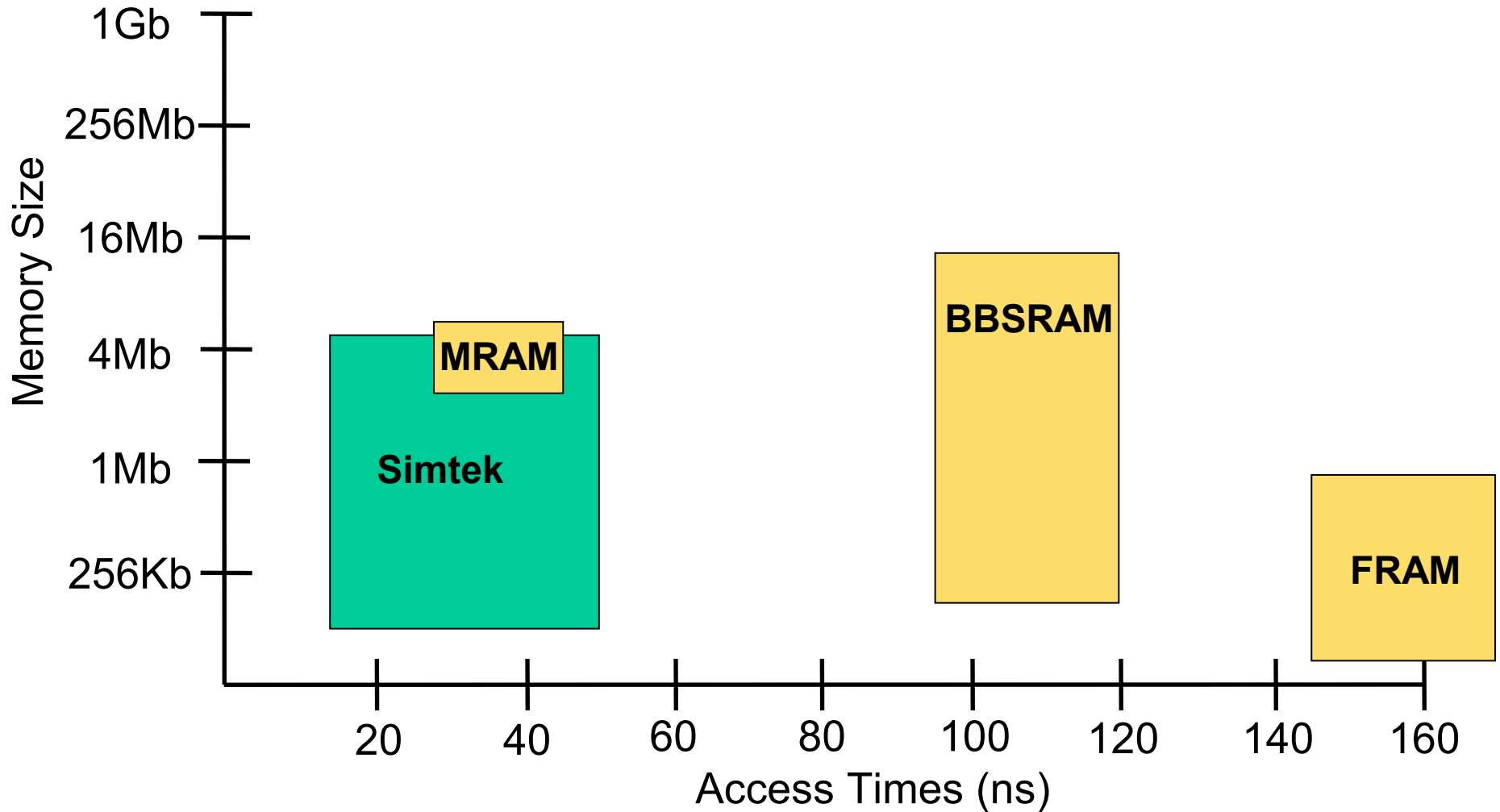

- **Corporate Overview**
- **Product Introduction**
- **Product Roadmap**
- **Competition**
  - **BBSRAMs**

**BBSRAM**

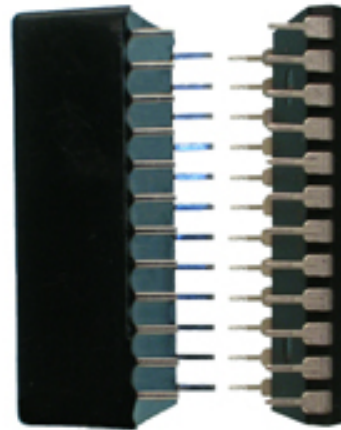

**nvSRAM**

Category	BBSRAMs	nvSRAMs
System Cost	Higher due to yield losses and assembly costs for integration of battery, SRAM and Vswitch circuit	Lower market pricing
Reliability	<p>Lower reliability inherent with the use of the battery and snap hat due to:</p> <ul style="list-style-type: none"> <li>• Snap hat will fall off in assembly and in the field</li> <li>• Battery can be corrosive</li> <li>• Batteries have higher PPM due to higher likelihood of failure</li> <li>• Batteries significantly effected by heat</li> </ul>	<p>High reliability associated with:</p> <ul style="list-style-type: none"> <li>• Elimination of the snap pack for the battery</li> <li>• Elimination of potential corrosive material</li> <li>• Elimination of potential battery failure</li> <li>• nvSRAMs minimally effected by heat</li> </ul>
Access Times	70 ns	25 – 45 ns
Height	Very high to accommodate the battery. Max height is 9.65 mm	Low profile. Max height is 2.8 mm
Data Retention	10 years	20 years
Temp Support	Commercial, Industrial	Commercial, Industrial and Military

Category	BBSRAMs	nvSRAMs
Hardware and firmware design	<ul style="list-style-type: none"> <li>• No specialized write procedures, easy on F/W</li> </ul>	<ul style="list-style-type: none"> <li>• No specialized write procedures, easy on F/W</li> <li>• No need to gauge battery life and develop scheme for data recovery after power loss</li> </ul>
ROHS	<ul style="list-style-type: none"> <li>• Batteries have hazardous waste material</li> </ul>	<ul style="list-style-type: none"> <li>• No hazardous material</li> </ul>
Manufacturing	<p>More difficult to manufacture due to:</p> <ul style="list-style-type: none"> <li>• Can't flow solder directly. Requires two solder flows</li> <li>• Requires a socket for single solder flow process</li> <li>• Yield loss due to insertion process</li> <li>• Requires hand insertion into the socket, requiring a secondary step just to deal with the battery</li> <li>• Even with snapat package, this requires a secondary step for addition of the battery.</li> <li>• More inventory of components</li> <li>• Need to track shelf life of battery</li> </ul>	<p>Higher manufacturing yield and capacity due to:</p> <ul style="list-style-type: none"> <li>• Single solder flow assembly.</li> <li>• No insertion or secondary steps</li> <li>• No hand or manual placement</li> </ul>

- Corporate Overview
- Product Introduction
- Product Roadmap
- **Competition**
  - BBSRAMs
  - **FRAMS**

- **Be Careful of the Ramtron Marketing Propaganda**
- **Ramtron claims a 60 ns part for their 1Mb FRAM, and marks it appropriately on the package**
- **This is only part of the truth!**
  - Their read/write cycle time for commercial temp is 150 ns, 6 times slower than Simtek's 1 Mb
  - Their read/write cycle time for industrial temp is 350 ns, 14 times slower than Simtek's 1 Mb
  - The 60 ns access is for Chip Enable access, a non-standard way of operation during regular microprocessor accesses. But it doesn't include a 90 ns pre-charge time.



# Simtek vs Ramtron 1 Mb Commercial

Specification	Simtek 1 Mb STK14CA8	Ramtron 1 Mb FM20L08
Read Cycle Time (ns)	25 - 45	150
Write Cycle Time (ns)	25 - 45	150
Chip Enable Access Time (ns)	25 - 45	60
Temperature Range (°C)	0 to 70	-20 to 85
Data Retention (Years)	20	10
Package	32 SOIC 48 SSOP	32 TSOP
Operating Voltage (V)	2.7 to 3.6	3.1 to 3.6

6x slower

This doesn't meet most system requirements

# Simtek vs Ramtron 1 Mb Industrial

Specification	Simtek 1 Mb STK14CA8	Ramtron 1 Mb FM20L08
Read Cycle Time (ns)	25 - 45	350
Write Cycle Time (ns)	25 - 45	350
Chip Enable Access Time (ns)	25 - 45	60
Temperature Range (°C)	-40 to 85	-40 to 85
Data Retention (Years)	20	10
Package	32 SOIC 48 SSOP	32 TSOP
Operating Voltage (V)	2.7 to 3.6	3.1 to 3.6

**14x  
slower**

**This doesn't meet  
most system  
requirements**

- **Corporate Overview**
- **Product Introduction**
- **Product Roadmap**
- **Competition**
  - **BBSRAMs**
  - **FRAM**
  - **MRAM**

Specification	Simtek 4 Mb STK14EC16	Freescale 4 Mb MR2A16A
Read Cycle Time (ns)	15 - 45	35
Write Cycle Time (ns)	15 - 45	35
Temperature Range (°C)	0 to 70 -40 to 85	0 to 70 -40 to 85 (Q207)
Data Retention (Years)	20	10
Package	44 TSOP II 54 TSOP II	44 TSOP II
Operating Voltage (V)	2.7 to 3.6	3.0 to 3.6
Operating Current (mA)	75	155*
Standby Current (mA)	1	28

\*Active write mode

- **Corporate Overview**
- **Product Introduction**
- **Product Roadmap**
- **Competition**
  - **BBSRAMs**
  - **FRAM**
  - **MRAM**
- **Applications**



# Sample nvSRAM Customers

Customer	End Systems
IBM, Dell, Adaptec, HP, LSI, Sun, Quanta, Intel, Fujitsu-Siemens	Servers, mass storage, RAID
Ricoh, Toshiba, Konica	Copiers, MFPs
Alcatel/Lucent, Adtran, Force 10 Networks	PBX, switches
BMW, Wabco, Motorola, Bosch	Air Bags, Engine control, Diagnostics
Metrima, ETG, Echelon, Landis & Gyr	Metering Systems
Sony, Matsushita, Hitachi	Commercial Video Camera, LCD Projectors
Bosch Rexroth, GE Funuc, SBS, Curtis-Wright, Phoenix, Schneider Electric, Siemens	Industrial Controls
EADS, General Dynamics, Lockheed Martin, BAE, Honeywell, Raytheon, Boeing, Titan	Military/Avionics, Weapons Systems

**Simtek has over 500 active customers and worldwide recognition**

- **Copiers**
- **Numeric Control**
- **ATM**
- **POS**
- **Medical Devices**
- **Gas Reader**
- **Train Brake Control**
- **Flight Control and Display**
- **KVM**
- **Avionics**
- **Uninterrupted Power Supplies**
- **GPS Applications**
- **Medical LANs**
- **Guidance Systems**
- **Navigation Control**
- **Blood Analysis**
- **Basketball Throwing Machine**
- **Coin Changer**
- **Doll Claw Machine**
- **Gas Meter**
- **Automatic Metering**
- **CO2 Tester**
- **Landing System**
- **Prosthetics**
- **Casino Gaming Systems: Player tracking system**
- **Artificial Pumps**

- **Writing lots of data that has to be saved**
- **Write data quickly (every 50 ns) that is critical to be saved**
- **Want protection of data during a power-down condition**
- **Only need a small amount of data saved**

- **Application Function**
  - Stores file directory, RAID algorithm parameters, user data
  - Similar to FAT (File Access Table)
  - Can be used to re-build storage recall in case of power loss
- **Where**
  - Attached to any RAID controller used in server or storage array systems
- **Stored information**
  - LBA, sector information, mirror status, write status, read status
- **Simtek Unique Value Proposition**
  - Enables non-volatile protection with unlimited writes and reads
  - Data is written every 45 ns
  - A highly reliable solution, since no battery is incorporated

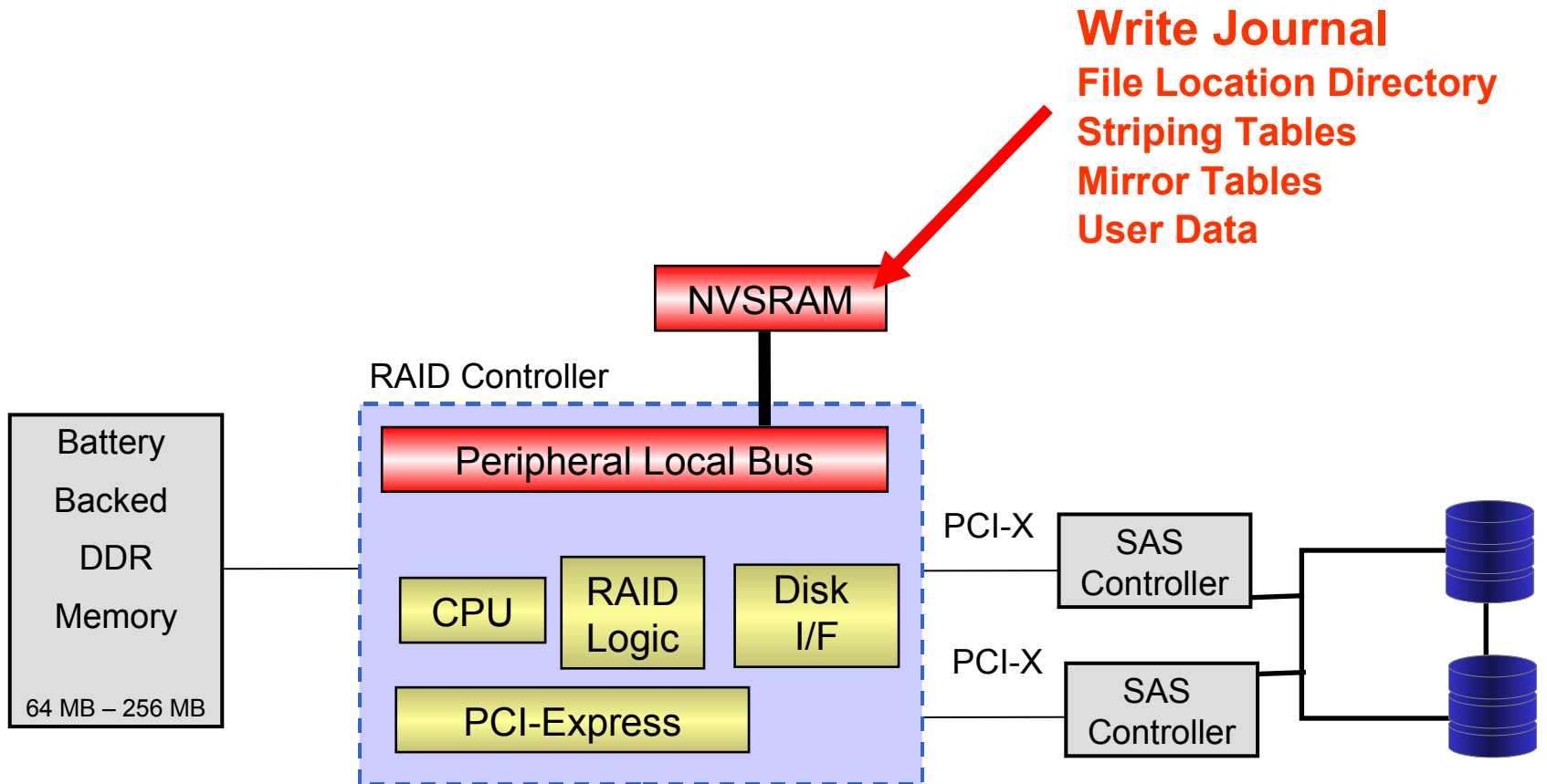

- **Application Function**
  - Real time diagnostics
  - Post mortem information when the system gets shipped back to the factory
- **Where**
  - Any line card (e.g. Ethernet, ATM, POTS, DS-3, DS-12, T1, E1)
- **Stored information**
  - Packet buffer pools, watermarks, active phone calls, # of connections, activity time profile, # of retries, alarm logs
- **Simtek Unique Value Proposition**
  - Can refer to the latest diagnostic parameters immediately on power-on after a major power loss
  - Can perform problem analysis and resolution remotely without concern for power loss

- **Application Function**
  - Robotics
  - Allows robotics to restart in production mode quickly at the last known position
- **Where**
  - Servo Motor Drive or the Programmable Logic Controller
- **Stored information**
  - Axis positioning information
- **Simtek Unique Value Proposition**
  - High reliability. No batteries. Requires operation up to 10 years
  - Very fast response moving dangerous robotic arms to the safety position

- **Robots have sensors to:**
  - Locate a part
  - Verify its actions
  - Perform quality control of the final results of its process
- **Constant flow of information from sensors**
- **Power interruption requires arm movement to safety position.**
- **Manufacturers want to be back and running ASAP and not lose productivity. Need nvSRAM to provide last remaining position information and restart the production line.**

- **The Need**

- Operators need access inside the guard to clear jams or fix other malfunctions
- Instead of a complete shutdown, motion is controlled at safe limits
- Axis acceleration on the order of  $1 \text{ m/s}^2$  requires capture of last axis location in milliseconds

- **Trend**

- Safety function transitioning from the PLC to the intelligent motor drive

- **Benefit**

- Drive based safety has reaction times 400 times faster than a PLC or controller-based solution
- PLC based systems can move 200 – 800 mm versus intelligent drive based systems at 2 mm

## Simtek Use

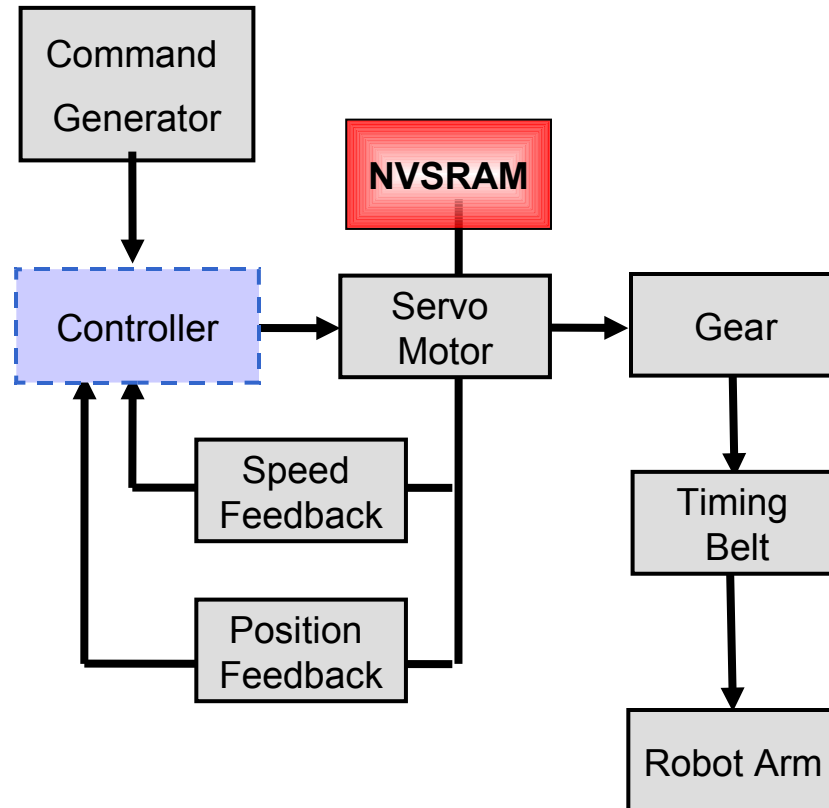

## Simtek Use

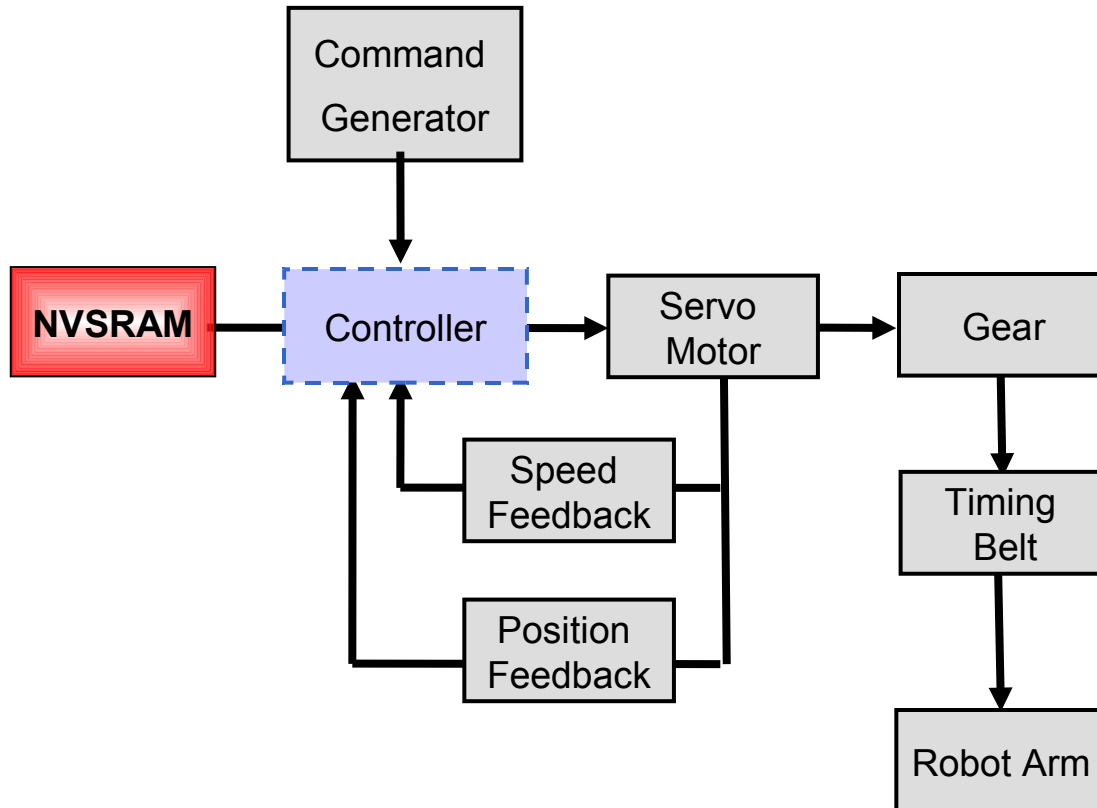

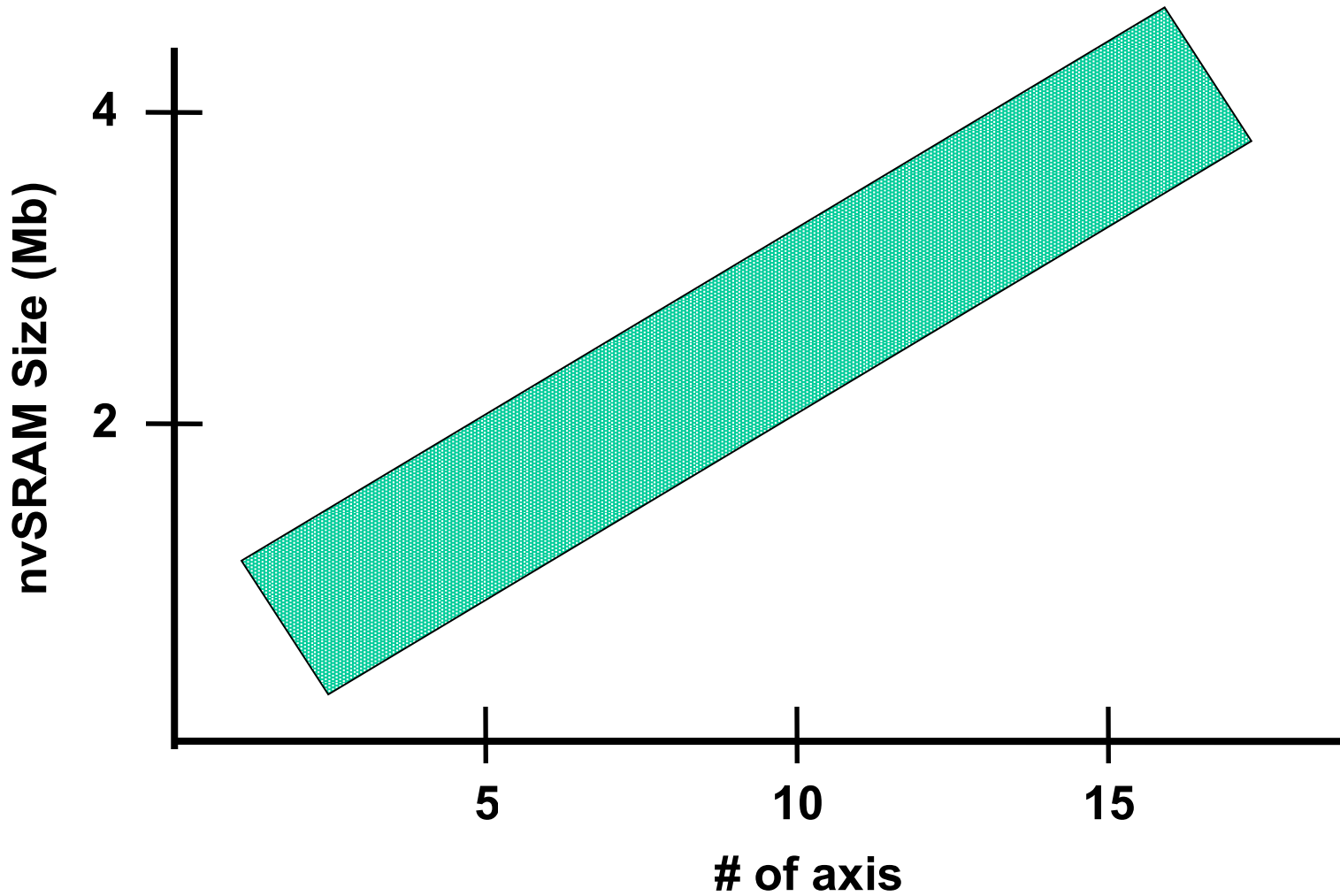

- Simtek nvSRAM is the only non-volatile with infinite writes and reads, combining the speed of SRAM and nonvolatile storage without the use of battery.
- Nonvolatile storage happens automatically during power loss.
- Used in a variety of applications where continual write of data and preventing data loss is important, under any potential power loss problem.
- Sample systems using nvSRAM are server storage, storage arrays, networks, medical devices, industrial control, copiers, avionics, GPS systems, automated meter reading (AMR), casino gaming machines, and POS systems.
- Powerful roadmap for future products planned in concert with process technology shrinks from 130 nm to 65 nm.

# **SONOS Processing and Roadmap**

## SONOS Memories (Silicon-Oxide-Nitride-Oxide-Silicon)

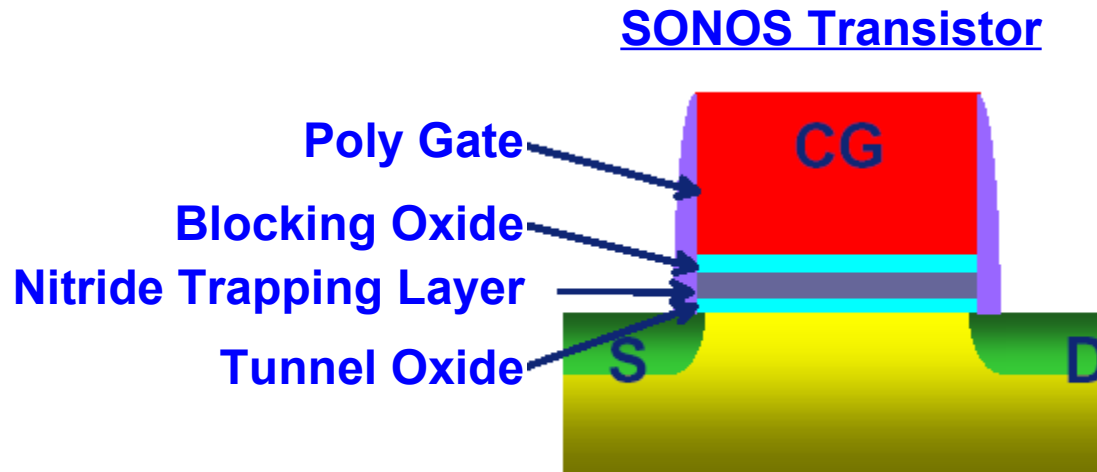

- Charge is stored in nitride layer which acts like floating gate
- Simple technology (topography, etching, ...)
- Easy to integrate in base-line CMOS processes.
- Direct tunneling (FN): lower program / erase voltages

## Operation of a SONOS device

### PROGRAM (positive voltage on gate)

- Electrons tunnel from substrate to trapping layer
- Electrons are trapped  
→  $V_T$  increases

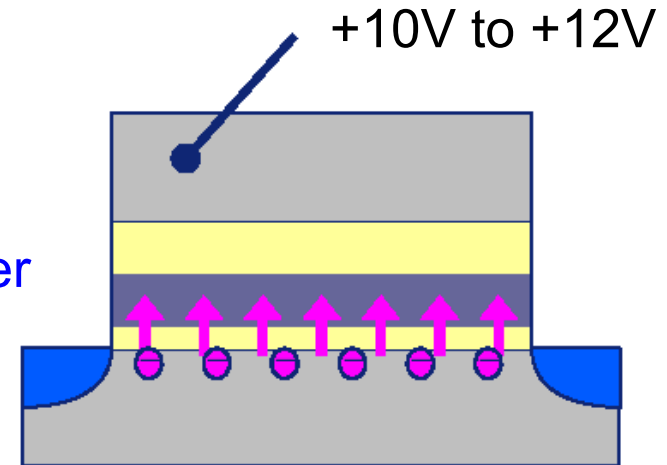

### ERASE (negative voltage on gate)

- Holes tunnel from substrate to trapping layer
- Holes recombine with trapped electrons  
→  $V_T$  decreases

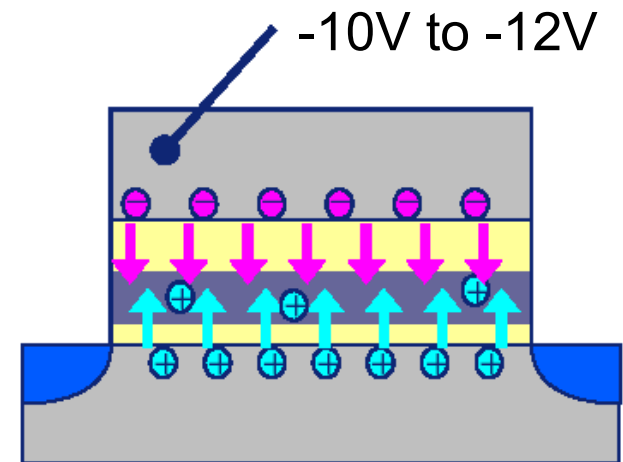

***Use Difference in  $V_T$  (or  $\Delta V_T$ ) to Represent Binary Data States***

- **Fast access nonvolatile random access memory**
- **Memory cell combines SRAM and Quantum Trap™ nonvolatile elements**
- **One array that functions as two independent memory arrays, SRAM and Quantum Trap™ NV elements**
  - The SRAM array is addressed like conventional SRAM
  - The Quantum Trap™ elements are accessed through the SRAM array.

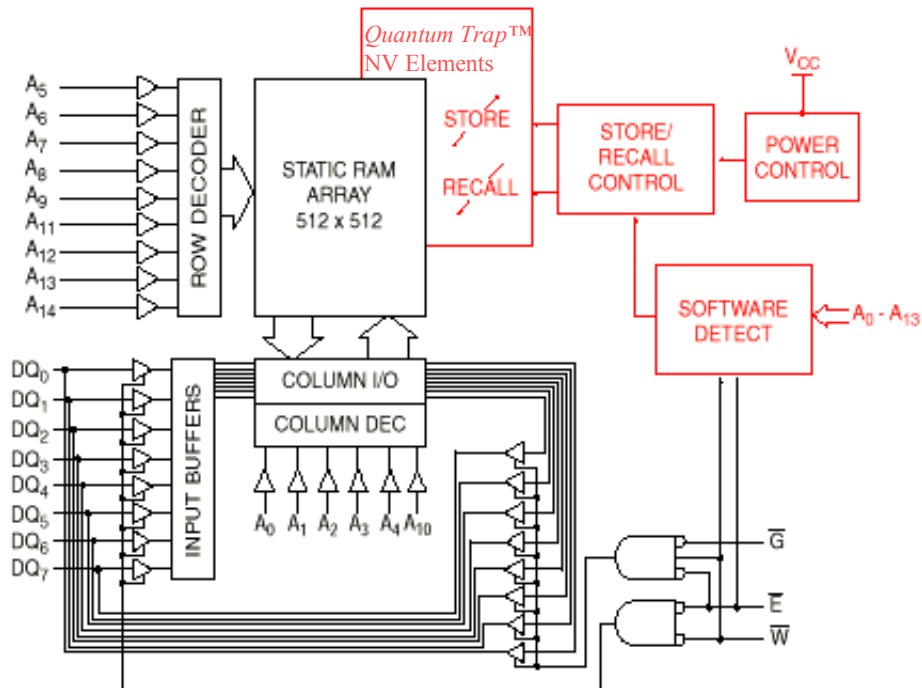

nvSRAM Cell Layout

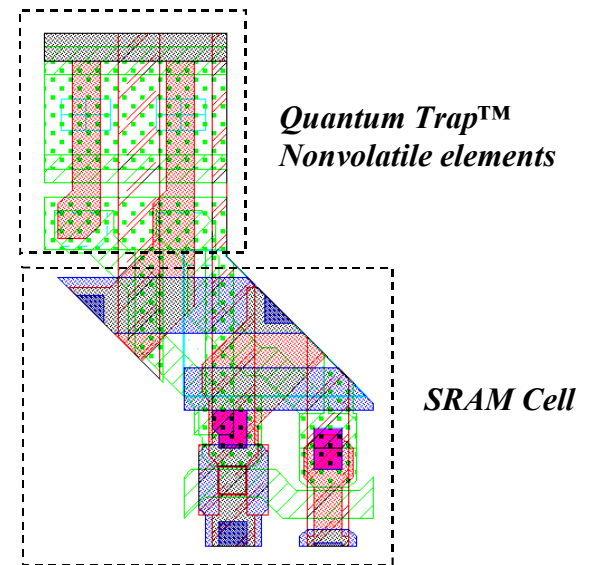



- **Chartered Semiconductor**
  - Current 16K, 64K, 256K
  - 0.8  $\mu\text{m}$ , 5volt, 3volt
- **Dongbu Semiconductor**
  - Current 1Mb nvSRAM, 1Mb & 256K RTC
  - .25  $\mu\text{m}$ , 3 volt
- **Cypress Semiconductor**
  - Future product 4Mb & others
  - 0.13  $\mu\text{m}$
  - 1Mb cost reductions